

◆ General Description

The GH1248/1250/1253 is an ultra-sensitive Hall-effect omnipolar switch IC with digital latched output, mainly designed for battery-operation, hand-held equipment.

Special CMOS process is used for low-voltage and low-power requirement. A chopper stabilized amplifier improves stability of magnetic switch points. The circuit design provides an internally controlled clocking mechanism to cycle power to the Hall sensor and analog signal processing circuits. This serves to place the high current-consuming portions of the circuit into a “Sleep” mode. Periodically the device is “Awakened” by this internal logic and the magnetic flux from the Hall sensor is evaluated against the predefined thresholds. If the flux density is above or below the B_{OP}/B_{RP} thresholds then the output transistor is driven to change states accordingly. While in the “Sleep” cycle the output transistor is latched in its previous state. The design has been optimized for service in applications requiring extended operating lifetime in battery powered systems.

The IC switching behaviour is omnipolar, either north or south pole sufficient strength will turn the output

on. If the magnetic flux density is larger than operating point (B_{OP}), the output will be turned on; if it is less than releasing point (B_{RP}), the output will be turned off.

The GH1248/1250/1253 is available in SIP-3L (or TO-92S), SOT23-3L packages which are optimized for most applications.

The DFN1616-3 package is another optional type.

◆ Features

- On Chip Hall Effect Sensor
- Micropower Operation
- 2.5 to 5.5V Power Supply
- Switching for Both Poles of a Magnet
- Chopper Stabilized amplifier stage
- Superior Temperature Stability
- Digital Output Signal
- Built-in Pull-up Resistor (GH1248/GH1250)
- Push-Pull CMOS Output Stage(GH1253)

◆ Applications

- Solid State Switch
- Handheld Wireless Handset Awake Switch
- Lid close sensor for battery-powered devices
- Magnet proximity sensor for reed switch replacement in low duty cycle applications

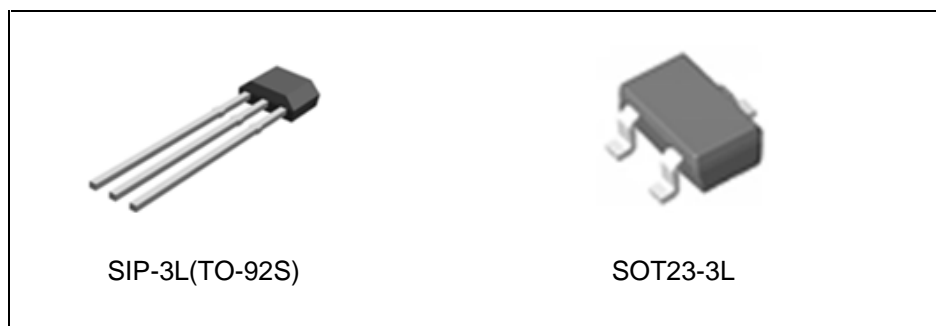

Figure 1. Package Type of GH1248/1250/1253

◆ Ordering Information

Package	Temperature Range	Part Number	Marking ID	Packing Type
SIP-3L(TO-92S)	-40 to 85 °C	GH1248EUA	G248	Bulk
SOT23-3L	-40 to 85 °C	GH1248ESW	G248	Tape and Reel
SIP-3L(TO-92S)	-40 to 85 °C	GH1250EUA	G250	Bulk
SOT23-3L	-40 to 85 °C	GH1250ESW	G250	Tape and Reel
SIP-3L(TO-92S)	-40 to 85 °C	GH1253EUA	G253	Bulk
SOT23-3L	-40 to 85 °C	GH1253ESW	G253	Tape and Reel

Note: The DFN1616-3 package is another optional type.

◆ Pin Configuration (Not to Scale)

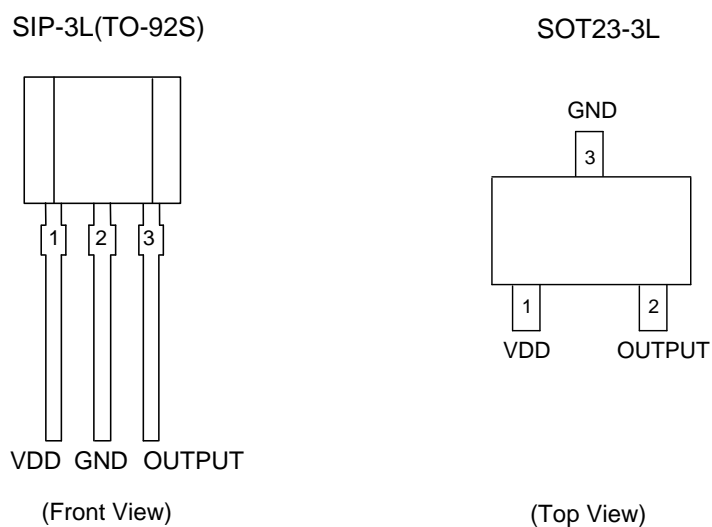

Figure 2. Pin Configuration of GH1248/1250/1253

◆ Pin Description

Pin Number			Pin Name	Function
SIP-3L	SOT23-3L	DFN1616-3		
1	1	1	VDD	Power Supply
2	3	3	GND	Ground pin
3	2	2	OUTPUT	Output pin

◆ Functional Block Diagram

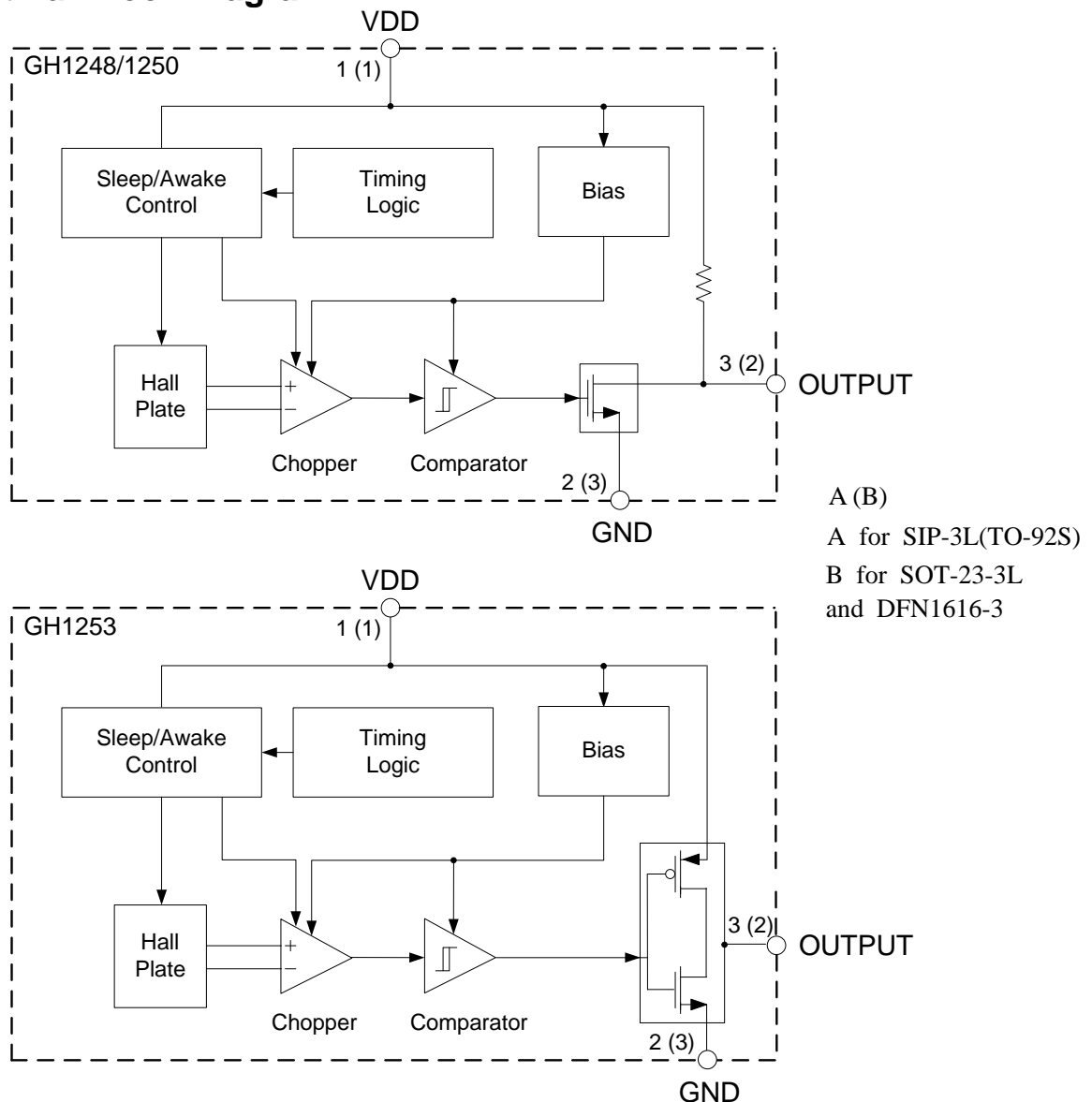

Figure 3. Functional Block Diagram of GH1248/1250/1253

◆ **Absolute Maximum Ratings (T_A=25°C, Note 1)**

Parameter	Symbol	Value	Unit
Supply Voltage	V _{DD}	-0.3~6.0	V
Supply Current (Fault)	I _{DD}	5.0	mA
Output Voltage	V _{OUT}	-0.3~6.0	V
Output Current	I _{OUT}	5.0	mA
Magnetic Flux Density	B	Unlimited	Gauss
Power Dissipation	P _D	SIP-3L	400
		SOT23-3L	230
Storage Temperature	T _{STG}	-55 to 150	°C
Junction Temperature	T _J	150	°C

Note 1: Stresses greater than those listed under “Absolute Maximum Ratings” may cause permanent damage to the device. These are stress ratings only, and functional operation of the device at these or any other conditions beyond those indicated under “Recommended Operating Conditions” is not implied. Exposure to “Absolute Maximum Ratings” for extended periods may affect device reliability.

Note 2: Electronic semiconductor products are sensitive to Electro Static Discharge (ESD). Always observe Electro Static Discharge control procedures whenever handling semiconductor products.

◆ **Recommended Operating Conditions**

Parameter	Symbol	Min	Max	Unit
Supply Voltage	V _{DD}	2.5	5.5	V
Operating Temperature	T _{OP}	-40	85	°C

◆ **Electrical Characteristics**

$V_{DD}=3.0V$, $T_A = 25^{\circ}C$, unless otherwise specified.

Parameter	Symbol	Conditions	Min	Typ	Max	Unit
Supply Voltage	V_{DD}	Operating	2.5	3.0	5.5	V
Supply Current	I_{SOP}	AWake(Operating)	-	1.0	2.0	mA
	I_{SL}	Sleep(Standby)	-	1.0	2.0	μA
	I_{SAVG}	Average	-	5.0	20.0	μA
Output Current	I_{OUT}		1.0	-	5.0	mA
Output Leakage Current	I_{LEAK}	$B < B_{RP} $	-	<0.01	1.0	μA
Saturation Voltage	V_{SAT}	$I_{OUT} = 1.0mA$	-	0.05	0.25	V
Awake Time	t_{AW}	AWake(Operating)	50	100	200	μs
Sleep Time	t_{SL}	Sleep(Standby)	40	70	100	ms

◆ **Magnetic Characteristics**

$V_{DD}=3.0V$, $T_A = 25^{\circ}C$, unless otherwise specified.

GH1248EUA/GH1248ESW/GH1253EUA/GH1253ESW

Parameter	Symbol	Conditions	Min	Typ	Max	Unit
Operating point	B_{OP}	$B > B_{OP} , V_{OUT} = \text{low}(\text{output on})$		+/-16	+/-25	Gauss
Releasing Point	B_{RP}	$B < B_{RP} , V_{OUT} = \text{high}(\text{output off})$	+/-5	+/-10		Gauss
Hysteresis	B_{HYS}		2	6	15	Gauss

GH1250EUA/GH1250ESW

Parameter	Symbol	Conditions	Min	Typ	Max	Unit
Operating point	B_{OP}	$B > B_{OP} , V_{OUT} = \text{low}(\text{output on})$		+/-35	+/-50	Gauss
Releasing Point	B_{RP}	$B < B_{RP} , V_{OUT} = \text{high}(\text{output off})$	+/-10	+/-15		Gauss
Hysteresis	B_{HYS}		5	20	30	Gauss

◆ Magnetic Characteristics (Continued)

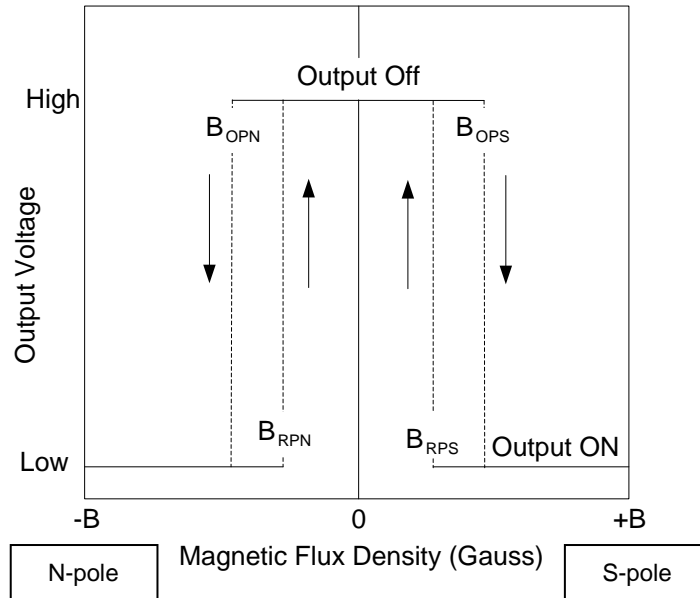

Figure 4. Output Voltage vs. Magnetic Flux Density

◆ Typical Application Circuit

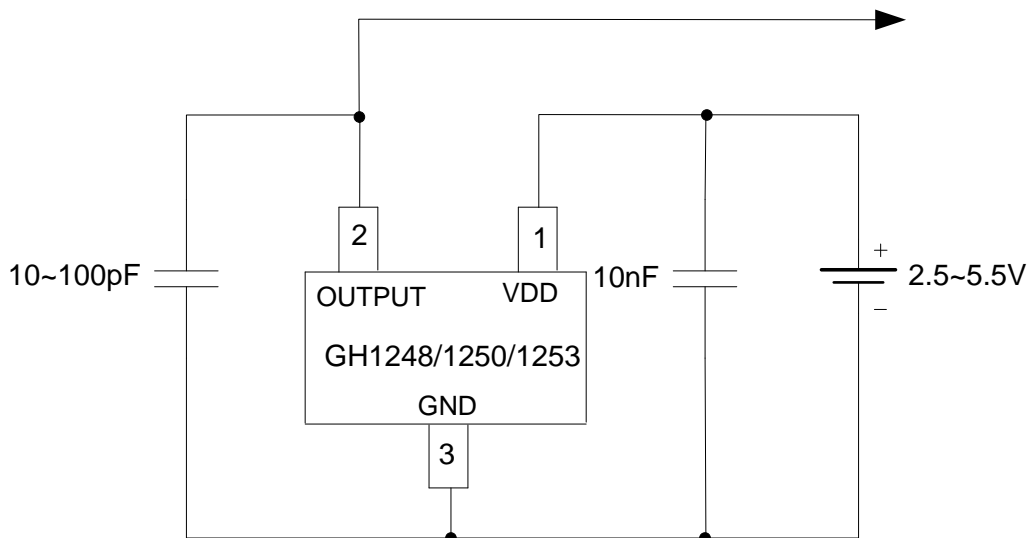
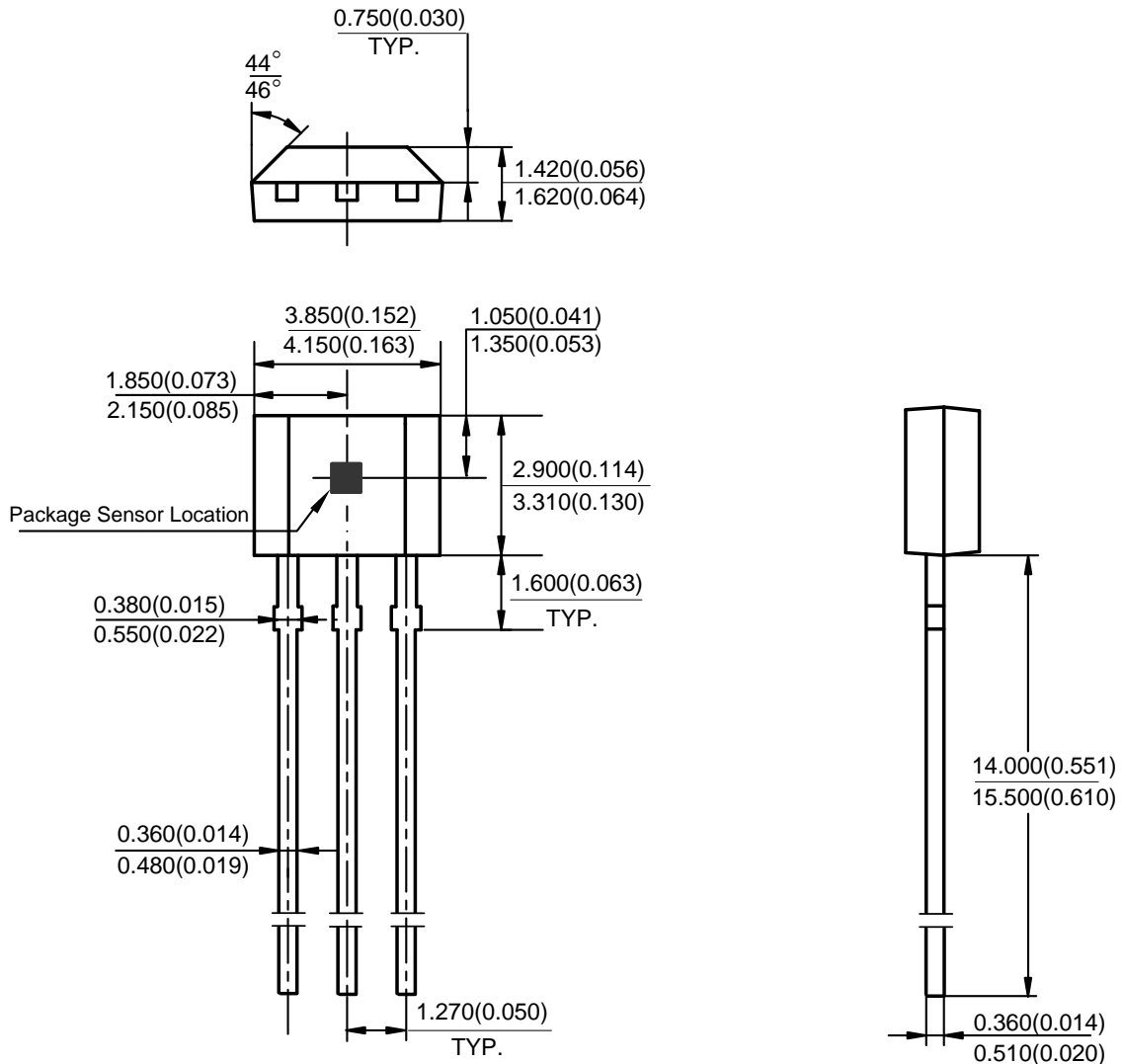

Figure 5. Typical Application of GH1248/1250/1253

◆ Mechanical Dimensions

SIP-3L(TO-92S) Unit: mm(inch)



◆ Mechanical Dimensions (Continued)

SOT23-3L Unit: mm(inch)

